

Aquagarden Tower

from **\$1,580** inc GST

1000 Litre Leader Tank & 2000, 3000 & 4000 Litre Units

Simply start with 1000 litre leader tank per below – then attach “add on” tanks in 1000 litre increments. There is no limit to amount of “add on” tanks.



All Units Supplied With

- Submersible pump
- Rainwater tank
- Pressure controller
- Operators manual
- Quality garden tap fitting
- “Rainwater Utilisation system in use” sign

Aquagarden Features

- Unlimited capacity – just keep adding tanks in 1000 litre increments
- Intelligent controller features power on, pump on and failure LED
- Demand pump – will shut off once you release trigger on hose or turn off tap
- Easily caters for Frogmouth filter which is sold separately
- No need to bend down to connect your garden hose. The attractive central panel locates the tap at a convenient height for you.

Aquagarden Benefits

- Aquagarden requires a single downpipe connection only, meaning less work and effort for you to install.
- Easy to install and requires only a single outdoor power point (10 Amp)
- Eliminates the frustration of buckets, watering cans and gravity tank systems
- Aquagarden is a complete system. It includes tank, pump, controller, garden tap and instruction manual.
- IP65 rating for you protection

Basic Specifications

- Power: 240-volt – (10 Amp)
- Pipe Connections: 90mm round
- Max Output: 320kpa at tap
- Max Head: 30m

Aquagarden Dimensions

Code: **AG1000******

Dimensions – 1000 litre System

Width: 1180mm (does not include plumbing or Frogmouth filter)

Height: From base to top of tank: 2010mm
From base to top of controller: 2178mm

Depth: 600mm

Dimensions – 1000 litre Add-on Tank

Code: **UE1000****AD**

Width: 1180mm

Height: From base to top of tank: 2010mm

Depth: 600mm

Systems are available in the following colour combinations

Colour Code (To order add colour code to the unit ordered *****)	Tank	Accessories, Cap, base, front panel
SCSC	Smooth Cream	Smooth Cream
SCMG	Smooth Cream	Mist Green
SCMB	Smooth Cream	Mountain Blue

1000 litre Aquagarden system

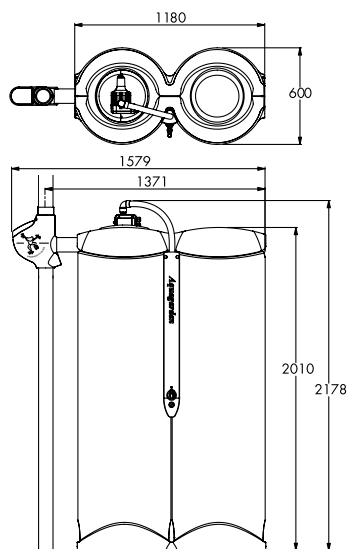

2000 Litre Aquagarden system

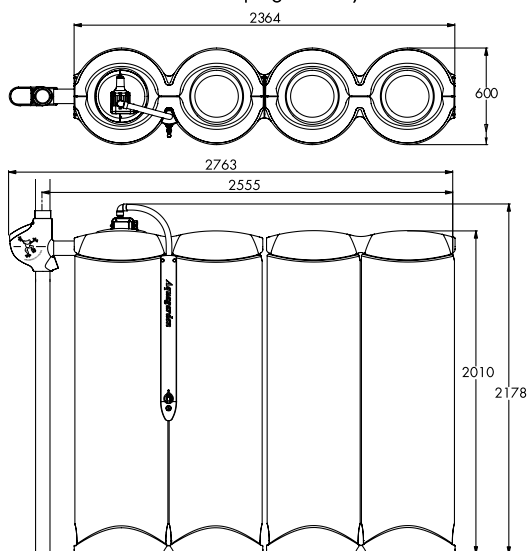

Tanks must be placed on a concrete slab or concrete pavers.
Base must be level and firm.

Warranty Policy

2 year warranty on Aquasource Interconnect Valve.

12 month warranty on all other components.

Frequently Asked Questions

Q: Do I need a stand for the tanks?

A: No, a concrete slab or pavers is required

Q: What is the maximum water capacity?

A: Each Aquagarden tank system holds 1000 litres, (add on tanks can be fitted at any time) Add on tanks hold 1000 litres.

Q: Will it work with my garden sprinkler or dripper system?

A: No

Q: Will the pump continue running if there is no water in tank?

A: No – the pump will detect if tank is empty and will not operate until the tank has a minimum 150mm of water in the bottom

Q: What is the maximum length of hose I can use?

A: Recommended hose length up to 30m – Hose length may be extended further but first check with manufacturer as there are many different factors which must be considered (gradient, temperature hose diameter etc).

Silvan Australia Pty Ltd – Melbourne Head Office
P.O. Box 4453
Dandenong South, Vic 3164
244 – 264 Greens Road
Dandenong South, VIC 3175

Silvan Australia Pty Ltd – Brisbane
Unit 5, 25 Industrial Crescent
Willawong, QLD 4110

Silvan Australia Pty Ltd – Perth
12 Cressall Road
Balcatta, WA 6021

Silvan New Zealand
22 Sunshine Ave, Te Rapa, New Zealand
P.O. Box 10088 Te Rapa,
Hamilton 3241, New Zealand
Phone: 07 849 6030, Fax: 07 849 6070
Web: www.silvannz.co.nz

Phone: 1300 SILVAN
(1300 745 826)

Fax: 1800 SILVAN
(1800 745 826)

Email: info@silvanaust.com
Web: www.silvanh2o.com.au

For further information contact
your nearest Silvan H₂O office
or go to www.silvanh2o.com.au

Silvan H₂O

Smarter rainwater systems

A division of Silvan Australia Pty Ltd