

Aquasource Tower

from \$2,050 inc GST

1000 Litre Leader Tank & 2000, 3000 & 4000 Litre Units

The complete Aquasource® system is a state-of-the-art, modular rainwater utilisation system designed to reduce a household's dependence on mains water for non-drinking purposes such as toilet flushing and laundry use.



All Units Supplied With

- Tank
- Pressure Controller
- Stainless Steel Submersible Pump
- Aquasource® mains water interconnect valve
- In line 'Y' filter
- Operators manual
- "Rainwater Utilisation system in use" sign

Aquasource Features

- The Aquasource® Interconnect Valve, controller and pump are matched to provide a highly efficient and synchronised system.
- Automatic water source changeover maximises the use of available rainwater.
- The Aquasource® Interconnect Valve is a certified Water Mark product.
- Valve is designed and manufactured to exacting specifications.
- High-flow transfer rate ensures greater application of water usage.

- Factory fitted backflow system that prevents contamination of the mains water connection.
- Stainless steel submersible pump provides cooler running in slim-line tanks and helps to maintain rainwater quality.
- Unlimited capacity – just keep adding tanks in 1000 litre increments
- Controller features a LED display panel that shows when the pump is running and when rainwater is available.
- The system does not allow mains water and rainwater to mix, therefore maximising potable water savings.
- Easily caters for Frogmouth & Lazy Lizard filters which are sold separately
- Ultra Slim (600mm) design ideal for narrow area's around the house.
- Recommend installation by licenced plumber

Basic Specifications

- Power: 240-volt – (10 Amp)
- Pipe Connections: 90mm round
- Flow rate of 60L/min at 25m head

Aquasource Dimensions

Dimensions – 1000 litre Leader System

Width: 1200mm (does not include plumbing or Frogmouth filter)

Height: From base to top of tank: 2010mm
From base to top of controller: 2200mm

Depth: 600mm

Dimensions – 1000 litre Add-on Tank

Width: 2400mm

Height: From base to top of tank: 2010mm

Depth: 600mm

Warranty Policy

2 year warranty on Aquasource Interconnect Valve.

12 month warranty on all other components.

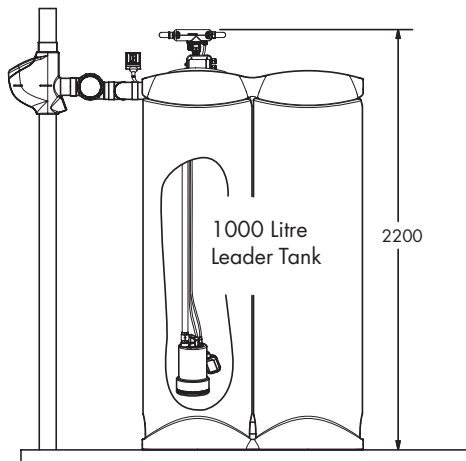
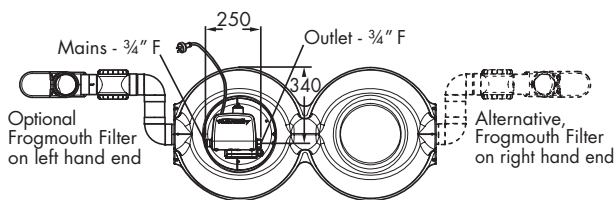

+

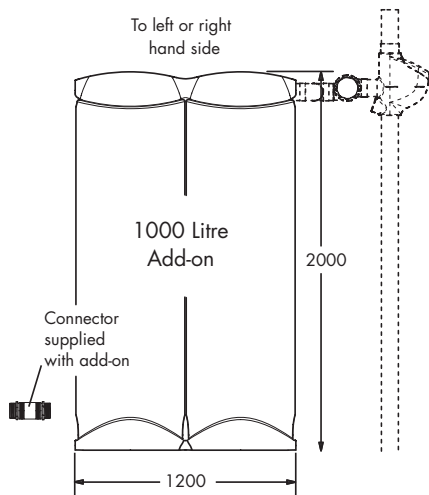

Add on tank can be positioned left or right hand side of leader tank. Frogmouth Filter can also be fitted left or right hand.

Systems are available in the following colour combinations

Tank	Cap & base panel colour
Smooth Cream	Smooth Cream
Smooth Cream	Mist Green
Smooth Cream	Mountain Blue

Frequently Asked Questions

Q: Do I need a stand for the tanks?

A: No, a concrete slab or pavers is required

Q: What is the maximum water capacity?

A: Each Aquasource tank system holds 1000 litres, (add on tanks can be fitted at any time) Add on tanks hold 1000 litres.

Q: Will the pump continue running if there is no water in tank?

A: No – the pump will detect if tank is empty and will not operate until the tank has a minimum 150mm of water in the bottom. If there is no water in the tank the system will revert to mains water.

Q: Will I still be able to flush my toilet if there is a power failure?

A: Yes – The system will switch to mains water supply.

Silvan Australia Pty Ltd – Melbourne Head Office
 P.O. Box 4453
 Dandenong South, Vic 3164
 244 – 264 Greens Road
 Dandenong South, VIC 3175

Silvan Australia Pty Ltd – Brisbane
 Unit 5, 25 Industrial Crescent
 Willawong, QLD 4110

Silvan Australia Pty Ltd – Perth
 12 Cressall Road
 Balcatta, WA 6021

Silvan New Zealand
 22 Sunshine Ave, Te Rapa, New Zealand
 P.O. Box 10088 Te Rapa,
 Hamilton 3241, New Zealand
 Phone: 07 849 6030, Fax: 07 849 6070
 Web: www.silvannz.co.nz

Phone: 1300 SILVAN
 (1300 745 826)
Fax: 1800 SILVAN
 (1800 745 826)

Email: info@silvanaust.com
 Web: www.silvanh2o.com.au

For further information contact
 your nearest Silvan H₂O office
 or go to www.silvanh2o.com.au

Silvan H₂O

Smarter rainwater systems

A division of Silvan Australia Pty Ltd